

# AMP CONDENSING WATER HEATERS - SUBMITTAL DATA SHEET

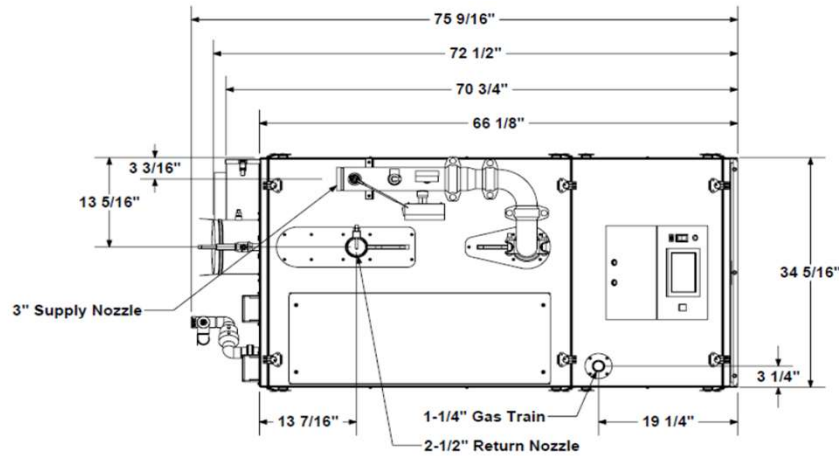

Top View

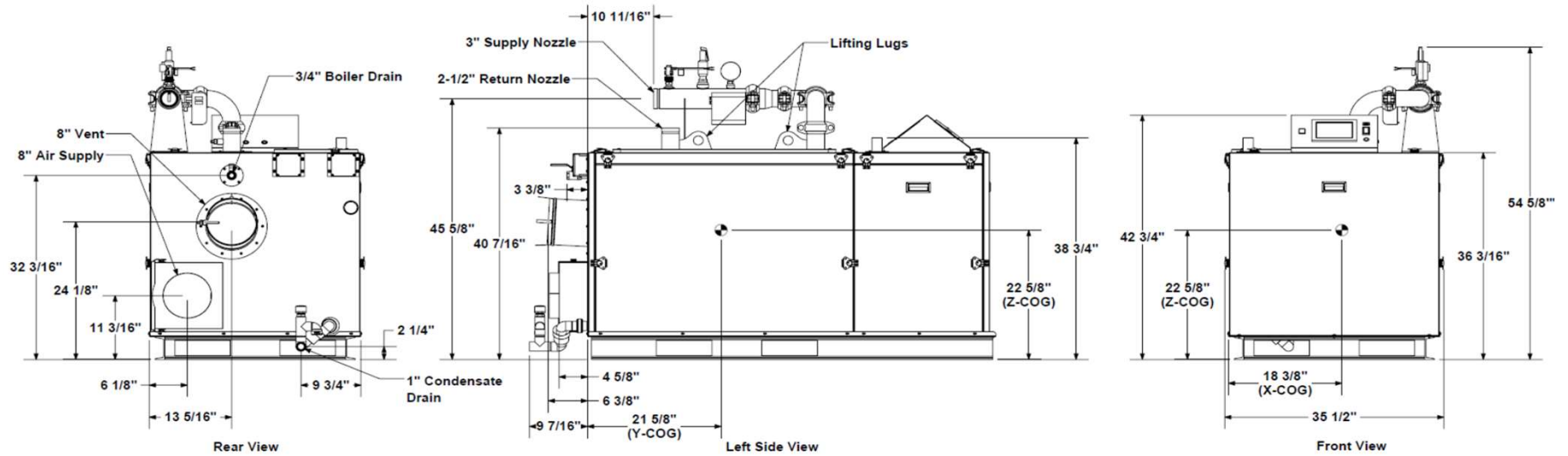



Rear View

Left Side View

Front View

 <p>Innovative Equipment for Hot Water Systems PO BOX 3244   LANCASTER, PA 17601</p>	<p>AMPW-1500</p>	<p>INNOVATIVE EQUIPMENT FOR HOT WATER SYSTEMS WWW.THERMALSOLUTIONS.COM</p>	<p>Updated 6/19/24 AMPW1500-20240602</p>
---	------------------	--	--

# AMP CONDENSING WATER HEATERS - SUBMITTAL DATA SHEET

RATINGS AND CAPACITIES		
Input - Low fire:	<b>300,000</b>	BTU/HR
Input - High Fire:	<b>1,500,000</b>	BTU/HR
Output - High Fire:	<b>1,470,000</b>	BTU/HR
DHW Recovery (40°F to 140° Rise):	<b>1,764</b>	GPH
Thermal Efficiency:	<b>98.0%</b>	
Heating Surface:	<b>119.8</b>	Sq.Ft.
Water Content:	<b>13.0</b>	Gallons
<b>Fuel: Natural Gas or LP Gas</b>		
<b>Firing Rate: Full Modulation</b>		
<b>Burner Turndown: 5:1</b>		
<b>Low NOx Emissions: &lt; 10 ppm</b>		
Inlet Gas Pressure (NG):	<b>4" wc</b>	Min.
Inlet Gas Pressure (LP):	<b>8" wc</b>	Min.
	<b>14" wc</b>	Max.
Shipping Weight, Approximate:	<b>1,217</b>	lbs
ASME Section IV (Max 160 PSIG / 210°F) Setpoint range is 60-185°F Adjustable, manual reset high limit setting of ≤ 200°F. ASME HLW stamp MAWT is 210°F for the vessel. (For max setpoint, see Setpoint range.)		
ETL Certified to ANSI Z21.10.3 / CSA 4.3		
NSF/ANSI Standard 372		
  		
DIMENSIONS / CONNECTIONS		
Height:	<b>42-3/4"</b>	(Note 1)
Width:	<b>34-1/4"</b>	(Note 2)
Length:	<b>66 1/8"</b>	(Note 3)
Supply Connection:	<b>3" Grooved</b>	
Return Connection:	<b>2-1/2" Grooved</b>	
Vent / Air Intake Connections:	<b>8"</b>	
Gas Connection:	<b>1 1/4" NPT</b>	

FLOW REQUIREMENTS		
Water Hardness	Flow (GPM)	r P (Ft. Hd)
4 - 12 gpg	<b>66</b>	<b>7.4</b>
12 - 15 gpg	<b>88</b>	<b>12.3</b>

- NOTES:**
1. Height dimension is from floor to top of jacket.
  2. Length is from jacket front to jacket rear.
  3. Dimensions shown are for reference only

# AMP CONDENSING WATER HEATERS - SUBMITTAL DATA SHEET

## STANDARD EQUIPMENT

### PRESSURE VESSEL DESIGN

Stainless Steel Heat Exchanger  
 ASME Section IV Certified, "HLW" Stamp (1000 - 2000)  
 ASME Section IV Certified, "H" Stamp (2500 - 4000)  
 MAWP 160 PSIG & Max Temp 210°F  
 Setpoint range is 60-185°F  
 Adjustable, manual reset high limit setting of ≤ 200°F.  
 ASME HLW stamp MAWT is 210°F for the vessel. (For max setpoint, see Setpoint range.)  
 Five Year Limited Heat Exchanger Warranty  
 Ten Year Limited Pressure Vessel Warranty

### COMBUSTION DESIGN

Stainless Steel Pre-Mix Burner  
 Low NOx Emissions (< 10 ppm)  
 Full Modulation, 5:1 Turndown  
 Natural Gas, Propane or Dual Fuel (Gas/Gas)  
 4" wc (8" wc Propane) to 14" wc inlet gas pressure  
 Direct Spark Ignition System with UV Scanner  
 High/Low gas pressure switches, manual reset  
 Zero governor gas valve  
 Variable Speed Combustion Blower  
 Air Proving Switch  
 Blocked Vent Switch  
 Manual fuel changeover switch (Dual Fuel Only)

### VENTING

Category II or IV Venting  
 Individual or Common (Engineered) Vent System  
 Vertical or Horizontal  
 CPVC, PP or SS Venting \*Materials Acceptable  
 Combustion Air Intake - Sealed or Room

\* Flue system material shall be capable of continuous operation at 210°F or higher and shall be certified to UL 1738 – venting system for gas-burning appliances cat II, III and IV.

### BOILER EQUIPMENT

Concert™ Control (24 Vac)  
 High Limit Temp Control, Manual Reset  
 Low water cutoff, manual reset  
 Water Flow Switch  
 Supply & Return Water Temperature Sensors  
 Flue Gas Temperature Sensor  
 Condensate trap  
 Blocked Condensate Switch  
 Pressure & Temperature Gauge  
 ASME Temperature & Pressure Safety Relief Valve, 150 psi

### ELECTRICAL DESIGN

#### Models 1000-2500:

- 120-208-230VAC/60HZ/1PH - High Voltage  
 (1500 to 2500 - Optional 208-230-460VAC/60HZ/3PH)

#### Models 3000:

- 208-230-240VAC/60HZ/1PH - High Voltage  
 - 208-230-240-460VAC/60HZ/3PH - High Voltage

#### Models 3500-4000:

- 208-230-240-460VAC/60HZ/3PH - High Voltage  
 - PCB (Printed Circuit Board) Fused Connections

#### 24VAC/5VDC - Low Voltage PCB

- EMS Communications  
 (Dual RJ45 Jacks for Peer-To-Peer or ModBus)  
 - Boiler Options (Sensors)  
 - Pumps (Boiler, DHW, System) & Auxiliary Devices

## OPTIONAL EQUIPMENT

External High Limit Temperature Control, Manual Reset

Condensate Neutralizer

Hot Water Header Temperature Sensor:

Direct Immersion

Well Immersion (with Well)

EMS Signal Converter Kit (Converts Energy or Building Management System 0-10v signal to 4-20mA)

Alarm Buzzer with Silencing Switch

Gas Valve Proving Switch

Vent Adapter - CPVC

Universal Communications Gateway (BACnet, Metasys, Modbus or Lonworks)

Stackable Rack

Conductor Sequencing Panel

The Conductor manages multiple condensing & non-condensing, small & large heat output, new and/or existing boilers (full modulation or on-off), and steam or hot water applications. It helps improve system efficiency by selecting and modulating the right boiler to match operating conditions. The Conductor offers a single point boiler plant Energy Management System (EMS) interface including Modbus TCP/IP, Modbus RTU RS485, BACnet/IP and BACnet MSTP standard. If Lonworks needed, add for the separate Lonworks gateway.

Extended Warranty

3-Year Parts

5-Year Parts

10-Year Parts

5-Year Parts/Labor

10-Year Parts/Labor

# AMP CONDENSING WATER HEATERS - SUBMITTAL DATA SHEET

## CONCERT CONTROL FEATURES

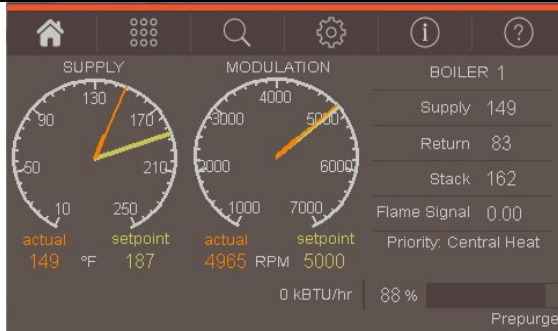

### **Dashboard - Color Touchscreen Display, 4"**

- Intuitive Icon Navigation
- "Quick" Setup Menus
- \*Real Time BTU/H Display

### **Temperature Demand Inputs**

- Time of Day Setback Capability  
(Envirocom Thermostat must be installed)

### **Two (2) Pump Control**

- System Pump
- Alternative Control to Combustion
  - Air Damper or Standby Loss Damper
- Pump Overrun for Heat Dissipation
- Pump Exercise
- Pump Rotor Seizing Protection
- Pump Overrun for Heat Dissipation

### **Peer-to-Peer Boiler Communications**

- Multiple Size Boiler Sequencing Up to 8 Units
- Lead Boiler Automatic Rotation

### **Energy Management System (EMS) Interface**

- \*Firing Rate and Water Temperature Based
  - Algorithms for Multiple Boilers; loss of EMS signal defaults to local boiler settings
- 420mAdc Input/Output (010Vdc Optional Converter)
- ModBus Input/Output (BACnet or LonWorks Optional Gateway)
- Simultaneous Interface with PeertoPeer

### **USB Data Port Transfer**

- Upload Settings Between Boilers
- Download Parameters for Troubleshooting
- Import Data into .CRV Formatted Files for Performance Analysis

\* Unique to Concert

### **Energy Efficiency Enhancer**

- AntiCycling Technology
- Multiplier boiler base load common rate
- Boost Temperature & Time
- Ramp Delay
- OverTemperature Safeguarding

### **Self-Guiding Diagnostics**

- Identifies Fault
- Describes Possible Problems
- Provides Corrective Actions
- Time/Date Stamp on Alarms and Lockouts

### **Unmatched Archives**

- Historical Trends Collects Up to 4 months Data
- Event History Up to 3000 Alarms, Lockouts and Cycle & Run Times
- Alarm Limit String Faults, Holds, Lockouts and Others
- Cycle & Run Time Boilers & Pumps
- Resettable (Lockouts/Alarms/Cycles & Run Time)

### **Other Features**

- Factory Default Settings
- Three Level Password Security
- Frost Protection
- Contractor Contacts (Up to 3)
- Low Water Flow Safety Control & Indication
- Proportion Integral Derivative (PID) Parameters for DWH, Sequencer and Fan
- Built-in Brown-Out Protection